

# TECHNICAL DATA

SINGLE DRUM ROLLERS (TIER3)

BW 216 D-5, BW 216 PD-5

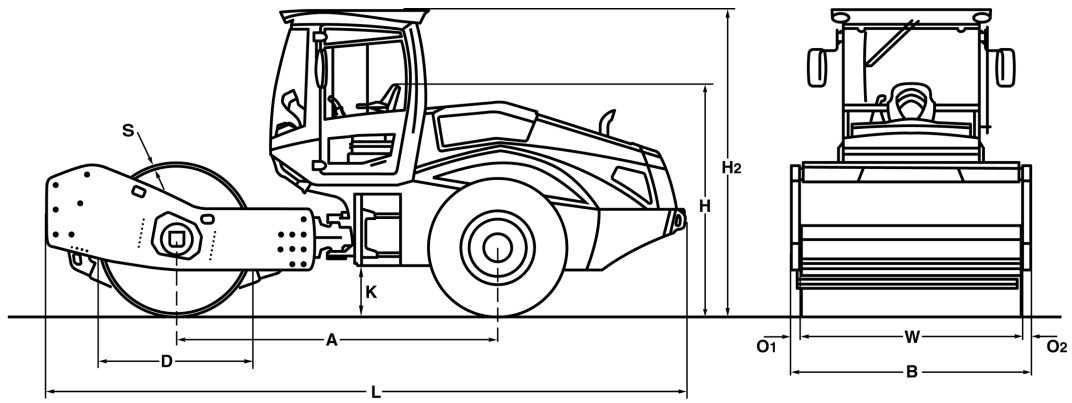



**Dimensions in mm**

	<b>A</b>	<b>B</b>	<b>D</b>	<b>H</b>	<b>H2</b>	<b>K</b>	<b>L</b>	<b>O1</b>	<b>O2</b>	<b>S</b>	<b>W</b>
<b>BW 216 D-5</b>	3113	2300	1500	2250	2990	490	6220	85	85	30	2130
<b>BW 216 PD-5</b>	3113	2300	1480	2250	2990	490	6220	85	85	25	2130

**Shipping dimensions in m3**

**BW 216 D-5**  
**BW 216 PD-5**

**without ROPS**

32,189  
32,189

**with ROPS**

42,775  
42,775

<b>Machine type</b>	<b>Compaction output (m3/h)</b>			
	<b>Rock fill</b>	<b>Gravel, sand</b>	<b>Mixed soil</b>	<b>Silt, clay</b>
BW 216 D-5	650-1200	450-920	340-680	210-420
BW 216 PD-5	650-1200	450-920	340-680	250-500

<b>Machine type</b>	<b>Compacted layer thickness (m)</b>			
	<b>Rock fill</b>	<b>Gravel, sand</b>	<b>Mixed soil</b>	<b>Silt, clay</b>
BW 216 D-5	1,10	0,75	0,55	0,30
BW 216 PD-5	0,90	0,75	0,55	0,55

**Technical Data****BOMAG  
BW 216 D-5****BOMAG  
BW 216 PD-5****Weights**

Grossweight .....	kg	17.910	17.950
Operating weight CECE w. ROPS-cabin .....	kg	15.990	17.100
Axle load, drum CECE .....	kg	10.800	11.900
Axle load, wheels CECE .....	kg	5.190	5.200
Static linear load CECE .....	kg/cm	50,7	

**Dimensions**

Working width .....	mm	2.130	2.130
Track radius, inner .....	mm	3.875	3.875

**Driving Characteristics**

Speed (1) .....	km/h	0- 3,0	0- 3,0
Speed (2) .....	km/h	0- 4,0	0- 4,0
Speed (3) .....	km/h	0- 5,0	0- 5,0
Speed (4) .....	km/h	0- 10,0	0- 10,0
Max. gradeability without/with vibr. ....	%	48/45	51/48

**Drive**

Engine manufacturer .....		Deutz	Deutz
Type .....		TCD 4.1 L4	TCD 4.1 L4
Emission stage .....		3/3	3/3
Cooling .....		Liquid	Liquid
Number of cylinders .....		4	4
Performance ISO 3046 .....	kW	115,0	115,0
Performance SAE J 1995 .....	hp	155,0	155,0
Speed .....	min-1	2.100	2.100
Fuel .....		diesel	diesel
Electric equipment .....	V	12	12
Drive system .....		hydrost.	hydrost.
Drum driven .....		standard	standard

**Drums and Tyres**

Number of pad feet .....			150
Area of one pad foot .....	cm <sup>2</sup>		137
Height of pad feet .....	mm		100
Tyre size .....		23.1-26 12PR	23.1-26 12PR

**Brakes**

Service brake .....		hydrost.	hydrost.
Parking brake .....		hydromec.	hydromec.

**Steering**

Steering system .....		oscil.artic.	oscil.artic.
Steering method .....		hydrost.	hydrost.
Steering / oscillating angle +/- .....	grad	35/12	35/12

**Exciter system**

Drive system .....		hydrost.	hydrost.
Frequency .....	Hz	30/36	30/36
Amplitude .....	mm	2,10/1,10	1,70/0,90
Centrifugal force .....	kN	285/220	285/217
Centrifugal force .....	t	29,1/22,4	29,1/22,1

**Capacities**

Fuel .....	l	250,0	250,0
------------	---	-------	-------

Technical modifications reserved. Machines may be shown with options.

### Standard Equipment

- BOMAG ECOMODE
- Warning, information and operation displays with LCD
- Noise insulation
- Hydrostatic travel and vibration drive
- Hydrostatic articulated steering
- Articulated joint lock
- Rear axle with twin spring accumulator brakes
- No-Spin differential lock
- Warning horn
- Single lever control for travel and vibration
- Seat with arm rest and adj. for position and height
- 2 Scrapers
- Emergency STOP
- Back-up alarm
- Working lights front / rear
- Tractor tires (PD)
- Loading mode
- Sliding window
- Battery disconnect switch

### Optional Equipment

- \* ROPS/FOPS cabin with seat belts
  - Sliding window
- ROPS/FOPS with safety belt
- Air condition
- Rearview camera
- TERRAMETER
- BOMAG ECOSTOP
- BOMAG TELEMATIC POWER
- Padfoot segment kit (D)
- Radio (Bluetooth)
- Indicator and hazard lights
- BCM 05 Documentation system
- Special painting
- Rotary beacon
- Pre start cabin heating
- Comfort package: Adjustable seat and adjustable steering column

\* Standard delivery with CE conformity  
(valid within European Union)

